

| NO. | REVISIONS | DATE | DEVISER |
|-----|-----------|------|---------|
| 1. | | | |
| 2. | | | |
| 3. | | | |

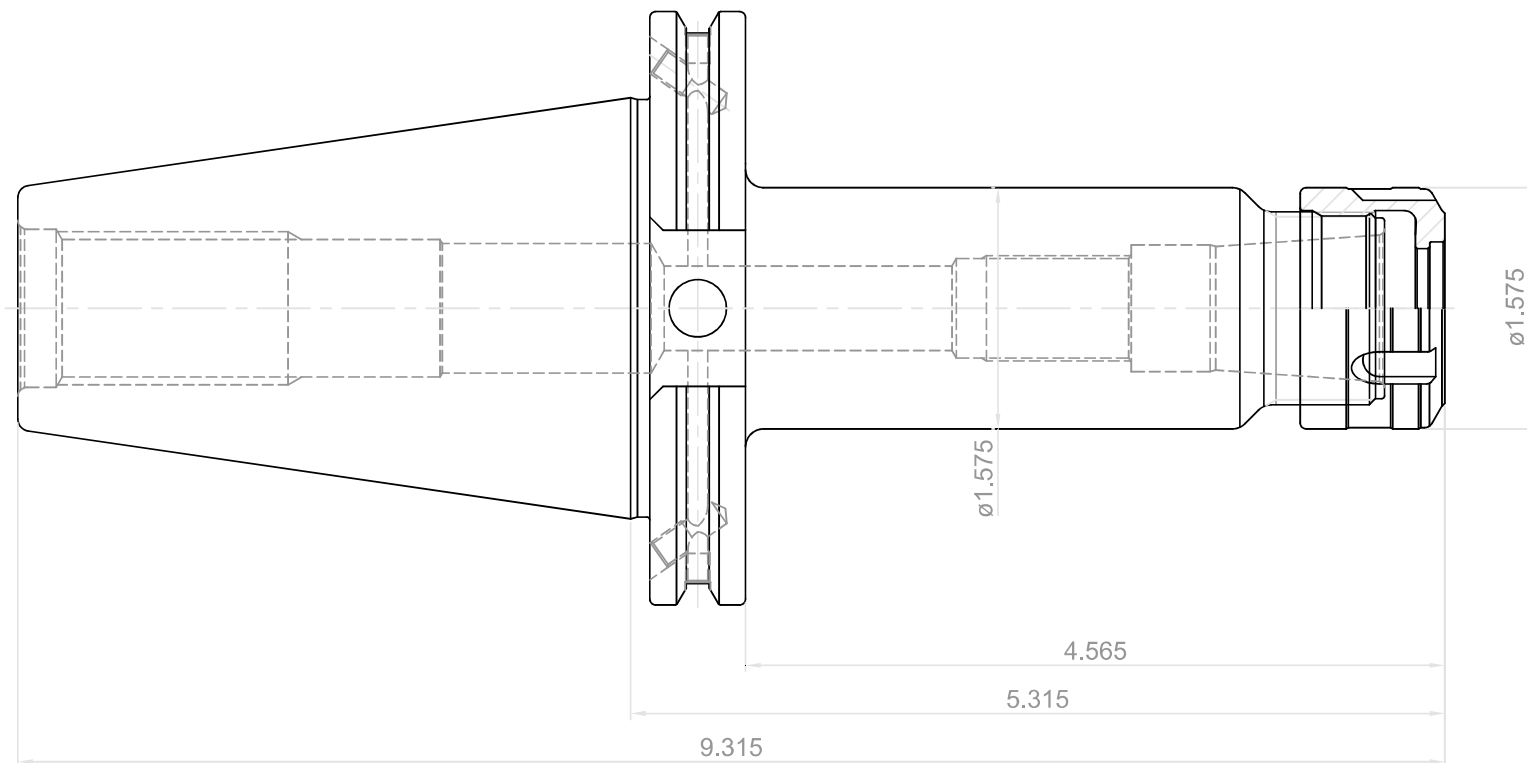

| | | |
|---|---------------------------|-------------|
|  YG-1 CO., LTD. | DESCRIPTION | |
| | CAT50AD/B-SKA16-5.31(135) | |
| EDP No. | TL033 | SCALE 1 : 1 |